



ClearSpan™ 34' Wide Free-Standing Building



Photo may show a model of a different length.

©2023 ClearSpan™
All Rights Reserved. Reproduction
is prohibited without permission.



WARNING: Cancer and Reproductive Toxicity - P65Warnings.ca.gov

STK#	DIMENSIONS
PB00650R4	34' W x 17' H x 48' L
PB00652R4	34' W x 17' H x 60' L
PB00654R4	34' W x 17' H x 72' L

Revision date: 04.27.23



YOU MUST READ THIS DOCUMENT BEFORE YOU BEGIN TO ASSEMBLE THE SHELTER.

Thank you for purchasing this ClearSpan™ shelter. When properly assembled and maintained, this product will provide years of reliable service. These instructions include helpful hints and important information needed to safely assemble and properly maintain the shelter. Please read these instructions **before** you begin.

If you have any questions during the assembly, contact Customer Service for assistance.

SAFETY PRECAUTIONS

- Wear eye protection.
- Wear head protection.
- Wear gloves when handling metal tubes.
- Use a portable GFCI (Ground Fault Circuit Interrupter) when working with power tools and cords.
- Do not climb on the shelter or framing during or after construction.
- Do not occupy the shelter during high winds, tornadoes, or hurricanes.
- Provide adequate ventilation if the structure is enclosed.
- Do not store hazardous materials in the shelter.
- Provide proper ingress and egress to prevent entrapment.

ANCHORING INSTRUCTIONS

Prior to assembling this shelter, please read the anchoring precautions and instructions included with the kit. Anchoring instructions are included in the **MUST READ** document. *You must anchor the building after the frame is assembled and before the cover is installed.*

⚠ WARNING: The anchor assembly is an integral part of the shelter construction. Improper anchoring may cause shelter instability and failure of the structure. Failing to anchor the shelter properly *will void the manufacturer's warranty* and may cause serious injury and damage.

LOCATION

Choosing the proper location is an important step before you begin to assemble the structure.

The following suggestions and precautions will help you determine whether your selected location is the best location.

- Never erect the structure under power lines.
- Identify whether underground cables and pipes are present *before* preparing the site or anchoring the structure.
- Location should be away from structures that could cause snow to drift on or around the building.
- Do not position the shelter where large loads such as snow and ice, large tree branches, or other overhead obstacles could fall.

SITE

After choosing a location, proper preparation of the site is essential. The following site characteristics will help ensure the integrity of the structure.

- The support structure must be level to properly and safely erect and anchor the frame.
- If the site is not level, use footing to provide a secure base for the structure. Pre-cast concrete blocks, pressure-treated wood posts, or poured footings are all acceptable when properly used.
- Drainage: Water draining off the structure and from areas surrounding the site should drain away from the site to prevent damage to the site, the structure, and contents of the structure.

⚠ WARNING: The individuals assembling this structure are responsible for designing and furnishing all temporary bracing, shoring and support needed during the assembly process. For safety reasons, those who are not familiar with recognized construction methods and techniques *must seek the help of a qualified contractor.*

ASSEMBLY PROCEDURE

Following the instructions as presented will help ensure the proper assembly of your shelter. Failing to follow these steps may result in an improperly assembled and anchored shelter and will void all warranty and protection the owner is entitled to.

The steps outlining the assembly process are as follows:

1. Verify that all parts are included in the shipment. Notify Customer Service for questions or concerns.
2. Read these instructions, the Must Read document, and all additional documentation included with the shipment **before** you begin assembling the shelter.
3. Gather the tools, bracing, ladders (and lifts), and assistants needed to assemble the shelter.
4. Check the weather **before** you install the roof cover and any panels (if equipped). Do not install covers or panels on a windy or stormy day.
5. Re-evaluate the location and site based on the information and precautions presented in the documentation included with the shipment.
6. Lay out the site (if this has not been completed).
7. Assemble the frame components in the order they are presented in these instructions.
8. Assemble the frame including the bracing (if equipped).
9. Consult the Must Read document for anchoring comments and instructions.
10. Install, tighten, and secure the end panel (if equipped) and main cover. This applies to fabric covers that stretch over the frame assembly.
11. Read the care and maintenance information at the end of these instructions.
12. Complete and return all warranty information as instructed.

LIST OF WORDS AND PHRASES

Before you begin, it is important to become familiar with the words and phrases used in this instruction manual.

These words and phrases are common to most ClearSpan™ shelters and identify the different parts of the shelter. (Some are used in this document. Others may not apply to this particular shelter.) These terms describe the shipped parts and can also be found on the materials list/spec sheets included with the shipment. To aid in the assembly, read through the following definitions before you begin to assemble your shelter.

- **Conduit:** An assembly of pipes used to secure the main cover and end panels (if equipped). Purlins and some strut assemblies also consist of connected pipes to form a conduit. Each pipe joint of a conduit assembly is secured with a self-tapping Tek screw.
- **Coupler or Fitting:** A part of the frame assembly where legs, purlins and rafter pipes are inserted and secured. In most instances, 3-way and 4-way couplers are used. In some larger applications, couplers are used to secure the joints of the different rafter sections during the assembly of the rafters. Some shelters do not use couplers.
- **Foot, Rafter Foot , or Base Plate:** The part attached to and found at the base of the rafter or leg of the shelter. Depending on the shelter, the foot is an optional purchase. Some shelters do not offer an optional foot. Some use 1-way connectors; others use ground posts.
- **Must Read Document:** This document includes building and shelter anchoring instructions, steps for end wall reinforcement, safety precautions, and notices and warnings. The Must Read document is sent with all shelters and buildings. If you did not receive a Must Read document, contact Customer Service to request one.
- **On-Center:** Term used to describe a measurement taken from the vertical center of the rafter or frame member to the vertical center of another.
- **Purlin or Angled (or Lateral) Bracing:** The pipe assemblies that run perpendicular to the rafters or framework that supports the main cover. These assemblies are found on the sides and roof areas of the assembled frame, are evenly spaced, and typically run from the front to the back of the shelter.
- **Plain or Straight Pipe:** A term used to describe a pipe that has the same diameter or width throughout its entire length.
- **Strut:** A strut is usually a length of pipe with two flattened ends and is used for diagonal bracing of the shelter frame. A strut is typically secured to the frame work by special brackets, bolts, and/or clamps.
- **Swaged End or Swaged Pipe:** The term "swaged" refers to the tapered end of the pipe or tube. Swaged ends of a pipe can be inserted into couplers and the straight ends of other pipes of the same diameter.
- **Tek Screw:** A self-tapping fastener used to secure pipe joints and to fasten brackets to rafters.

CLEARSPAN™ POLY BUILDINGS

REQUIRED TOOLS

The following list identifies the main tools needed to assemble the shelter. Additional tools and supports may be needed depending on the structure, location, and application.

- Tape measure or measuring device
- Marker
- Duct tape
- Magnetic nut setter (3/8" x 2-9/16")
- Variable speed drill and impact driver (cordless with extra batteries works best)
- Wrenches or ratchet and socket set (recommended)
- Scissors or utility knife to cut cover material and strap
- Tool to cut cable to the required length
- Hammers, gloves, and eye protection
- Ladders, work platforms, and other machinery for lifting designed to work safely at the height of the shelter
- Rope (or straps) for cover installation

UNPACK AND IDENTIFY PARTS

The following steps will ensure that you have all the necessary parts *before* you begin to assemble the shelter.

1. Unpack the contents of the shipment and place where you can easily inventory the parts. Refer to the Bill of Materials/Spec Sheets.
2. Verify that all parts listed on the Bill of Materials/Spec Sheets are present. If anything is missing or you have questions, consult the Pictorial Parts Guide and all shelter diagrams throughout these instructions for clarification, or contact Customer Service.

NOTE: At this time, you do not need to open the plastic bags containing the fasteners (if used).

QUICK START GUIDE

For a quick overview of this shelter and its components, consult the Quick Start Guide near the back of these instructions.

The pages of the Quick Start Guide show exploded views of all critical connections. Use the diagrams in the Quick Start section to assemble the frame of your building.

Consult the remainder of these instructions for important details that will help during the construction.

SPECIAL NOTE: Baseboards for Frame

These instructions recommend installing a baseboard under the mounting feet along each side of the frame. The baseboard runs from the front to the back of the building.

This baseboard is *not included* with the shipment and must be supplied by the customer. Treated or recycled plastic lumber works well for a baseboard.

The baseboard, when installed properly, helps prevent the shelter from sinking into the ground when anchored. Baseboards also provide a surface to attach rafter feet or other building components.

Consult these instructions, or contact Customer Service for additional information regarding baseboards.

ClearSpan

The following graphics and photos will help you identify the different parts of the building. Consult the Quick Start Guide for additional details and diagrams. (All parts are not shown.)



FA4482B
Tek Screw

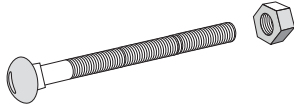

FAH325B & FALB32B
Carriage Bolt & Nut



QH1061
1" Ratchet



QH1070
Pipe Strap

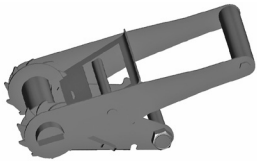

QH1065
2" Ratchet



103856
Band Clamp

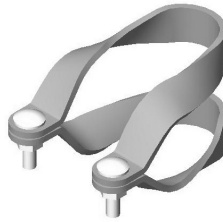

102546
Cross Connector

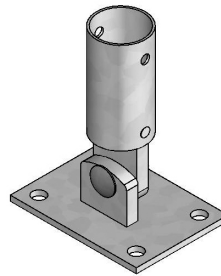

104302
Pipe Fitting w/Plate

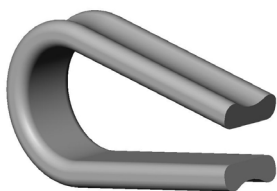

AS1083
3/16" Cable Thimble

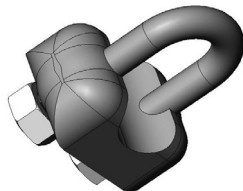

AS1003
3/16" Cable Clamp

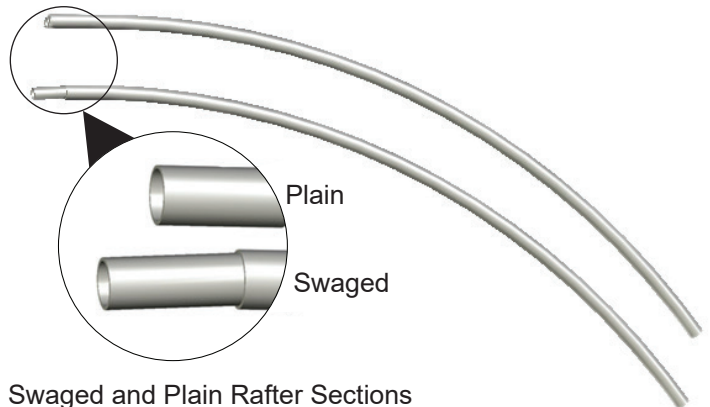

Swaged and Plain Rafter Sections
(not all pieces are shown)



104189 Turnbuckle



ClearSpan™ Free-Standing Building

The instructions that follow describe assembling all rafters and then constructing the frame. Depending on the number of individuals assisting with the construction, it may be best and more efficient to have someone assemble the rafters and others assemble the frame as rafters are completed.

Other factors to consider during the assembly, especially for buildings longer than 60', include:

- Amount of working area
- Available lifts and work platforms
- Number of assistants

OVERVIEW

This section describes assembling your free-standing building. For details of each assembly procedure, consult the Quick Start Guide and the individual sections of these instructions. See illustration below to identify main parts of shelter.

1. Layout the site and identify the required parts for each assembly procedure.
2. Assemble all rafters.
3. Assemble and anchor the frame.
4. Cut, assemble, and install all cables.
5. Prepare and install the main cover.

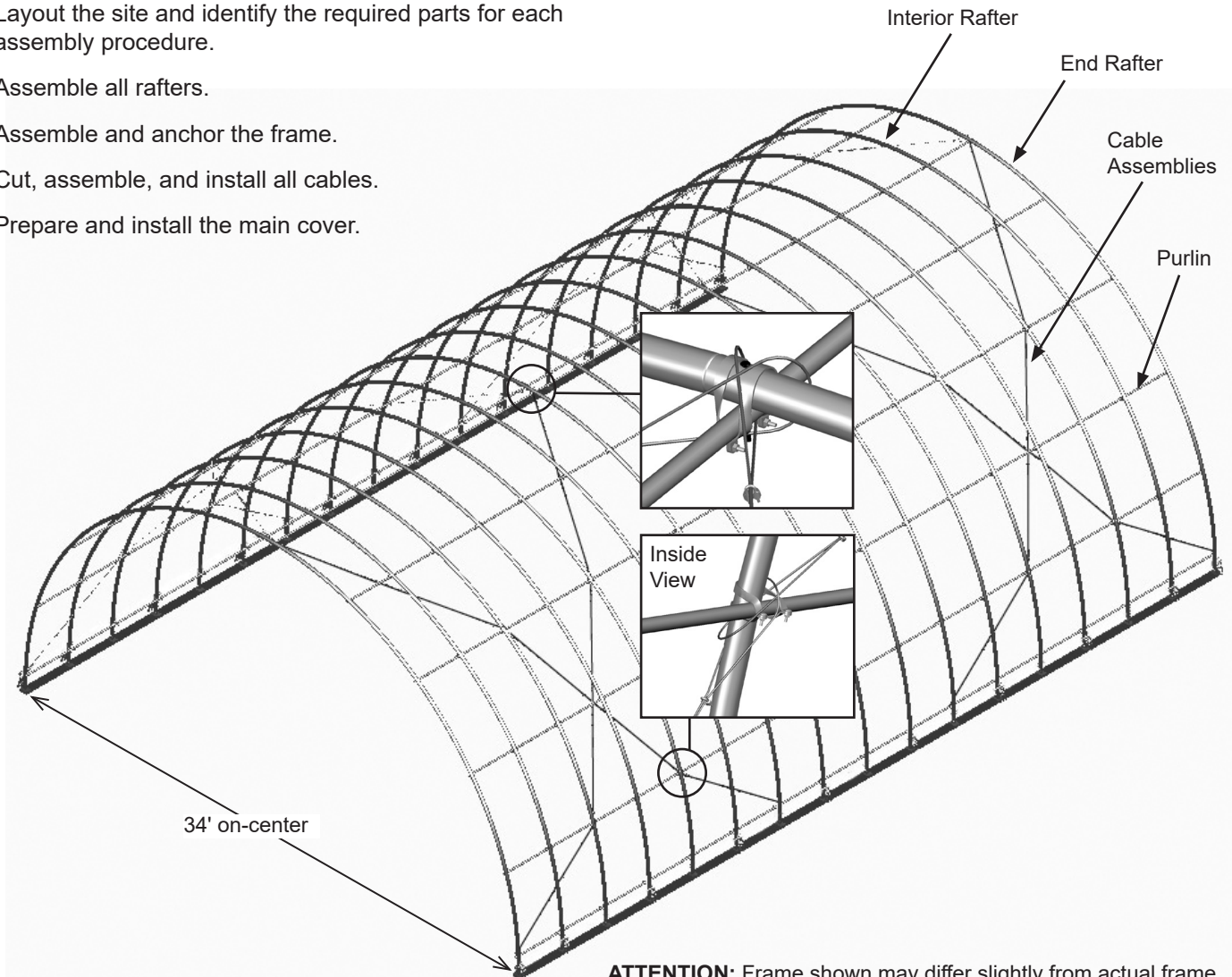

ATTENTION: Frame shown may differ slightly from actual frame.

LAY OUT THE BUILDING SITE

After the site is prepared, identify the location of the shelter corners helps to square the frame after it is assembled.

Taking these steps **before** assembling the shelter saves time and ensures that the structure is positioned as desired. The following procedure is a suggested method. Its use depends on the size of the shelter, shelter application, the footings, and the method used to anchor the shelter.

SQUARE THE SITE

1. Identify a corner where a building rafter will be positioned, drive in a stake, and string a line the exact width of the building and stake in place. (Width of the rafter is measured from center-to-center of the rafter legs.)
2. Sting a line at least as long as the building from the first stake at 90°.

NOTE: A transit can be used to ensure an accurate 90° angle, or the 3-4-5 rule can be used. Refer to diagram. Using multiples of 3-4-5 such as 6-8-10 or 12-16-20 helps to maintain an accurate 90° angle.

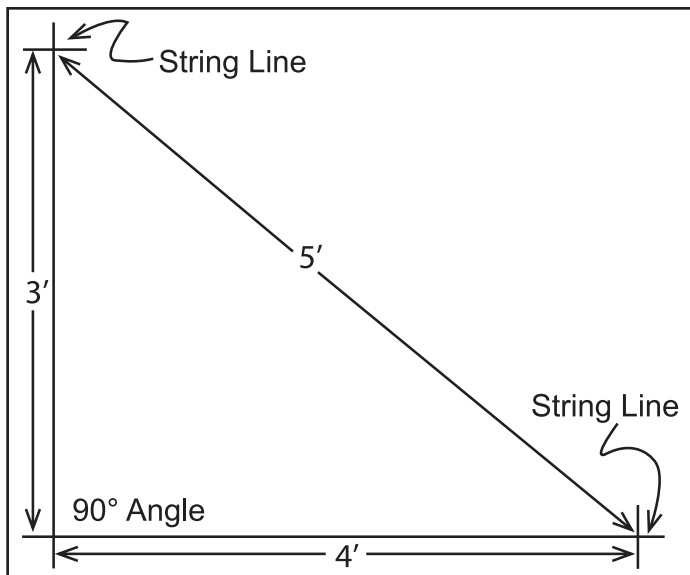

3. After squaring the position of the building and placing a stake at all corners, string a line between the stakes to mark the base of the building.
4. Next, paint or mark a line on the ground using the strings between the stakes as guides.

NOTE: Setting *customer-supplied* baseboards on the site in the correct positions is another way to prepare for the frame assembly.

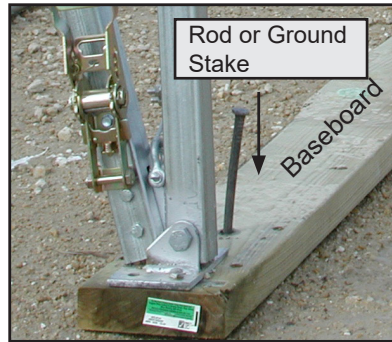

Actual rafter is not shown.

NOTE: If a baseboard is used, drill holes through the board at evenly-spaced intervals along the length of the board. Drive a rod through each hole and into the site to prevent the boards from shifting and to maintain the on-center width of the building.

The baseboards can be "pinned" in place using rods driven into the site through evenly-spaced holes drilled in the baseboard. This prevents the baseboards from shifting during assembly.

Building width is measured on-center.

5. After marking the outline of the building, continue with the rafter assembly instructions.



Space below is reserved for customer notes.

CLEARSPAN™ POLY BUILDINGS

ASSEMBLE THE FREE-STANDING BUILDING COMPONENTS

NOTE: Assistance is required to assemble the shelter.

END RAFTER ASSEMBLY (2)

Gather the parts:

- Rafter pipe (#34R23S1D) and 2 QH1065 ratchets
- Rafter pipe (#34R23S1) & rafter pipe (#34R23P2)
- Pipe strap (#QH1070) & band clamp (#103856)
- Rafter foot (#104302) & Tek screws (#FA4482B)
- FAG363B 3/8" x 3" bolt and FALB04B 3/8" nut

ATTENTION: After assembling the end rafters, set the two (2) identical rafters aside in an accessible place. One rafter is used at each end of the frame during the assembly.

Do not place other assembled interior rafters from the next procedure on the end rafter pile.

Assemble End Rafters

1. Connect the pipes as shown below. Each rafter assembly consists of five (5) pipes: 2 (#34R23S1D), 2 (#34R23S1), and 1 (#34R23P2). Each #34R23S1D pipe includes *one drilled hole near the bottom* used to connect the rafter foot.
2. With the rafter pipes assembled on the ground, secure each pipe joint using one self-tapping Tek screw (FA4482). Position screws so they will not interfere with the cover once it is installed.
3. Attach all (QH1070) brackets to the rafter using two (2) Tek screws for each strap. Attach the brackets to the underside of the rafter in the locations shown below and on the Front Profile diagram in the Quick Start section at the back of these instructions. The QH1070 straps should remain loose; do not fully tighten *at this time*.
4. Move to the end of each rafter leg and slide one (1) 103856 band clamp onto each leg.
5. Attach a ratchet (QH1065) and rafter foot to each leg of the rafter using a 3/8" x 3" bolt and 3/8" nut. Secure the *ratchet and foot using the same bolt and nut as shown. Ratchets can be attached to either the inside (not shown) or the outside (shown) of the rafter*. If installed on the *inside of the rafter leg*, position the bolt head to the outside of the rafter to prevent cover damage when it is installed.
6. With both rafter feet secured, measure 10" from the bottom of one rafter foot and mark a line on the inside of the rafter. Position the bottom of one QH1070 bracket on the line and secure it to the rafter. Strap should remain loose.
7. Repeat Step 6 to attach the remaining QH1070 strap to the rafter leg.
8. Repeat the steps to assemble the second end rafter.

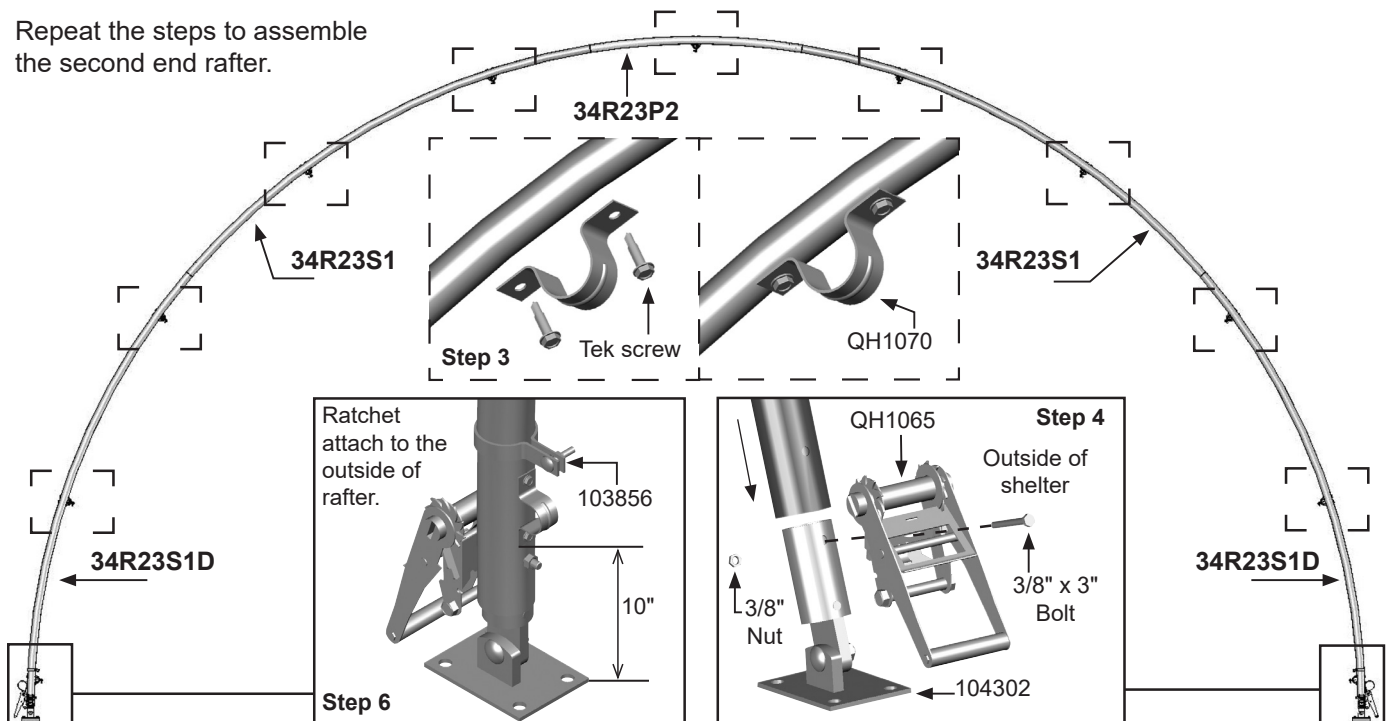

INTERIOR RAFTER ASSEMBLIES

Gather the parts:

- Rafter pipe (#34R23S1D)
- Rafter pipe (#34R23S1) & rafter pipe (#34R23P2)
- Rafter foot (#104302) & Tek screws (#FA4482B)
- FAG363B 3/8" x 3" bolt and FALB04B 3/8" nut
- QH1065 Ratchets

Assemble Interior Rafters With Attached Ratchets

1. Repeat Steps 1 and 2 from the End Rafter Assembly procedure on the previous page.
2. Attach a ratchet (QH1065) and rafter foot to each leg of the rafter using a 3/8" x 3" bolt and 3/8" nut. Secure the ratchet and foot using the same bolt and nut as shown. Ratchets can be attached to either the inside (not shown) or the outside (shown) of the rafter. If installed on the inside of the rafter leg, position the bolt head to the outside of the rafter to prevent cover damage when it is installed.
3. Repeat the steps to assemble the remaining interior rafters that include QH1065 ratchets. Consult the Side Profile Diagram in the Quick Start Guide near the back of these instructions to view the position and number of interior rafters with ratchets. Do not use the QH1061 ratchets during this procedure; use only the remaining QH1065 ratchets.

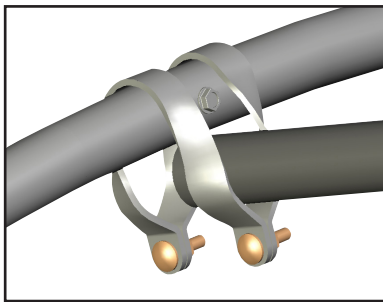
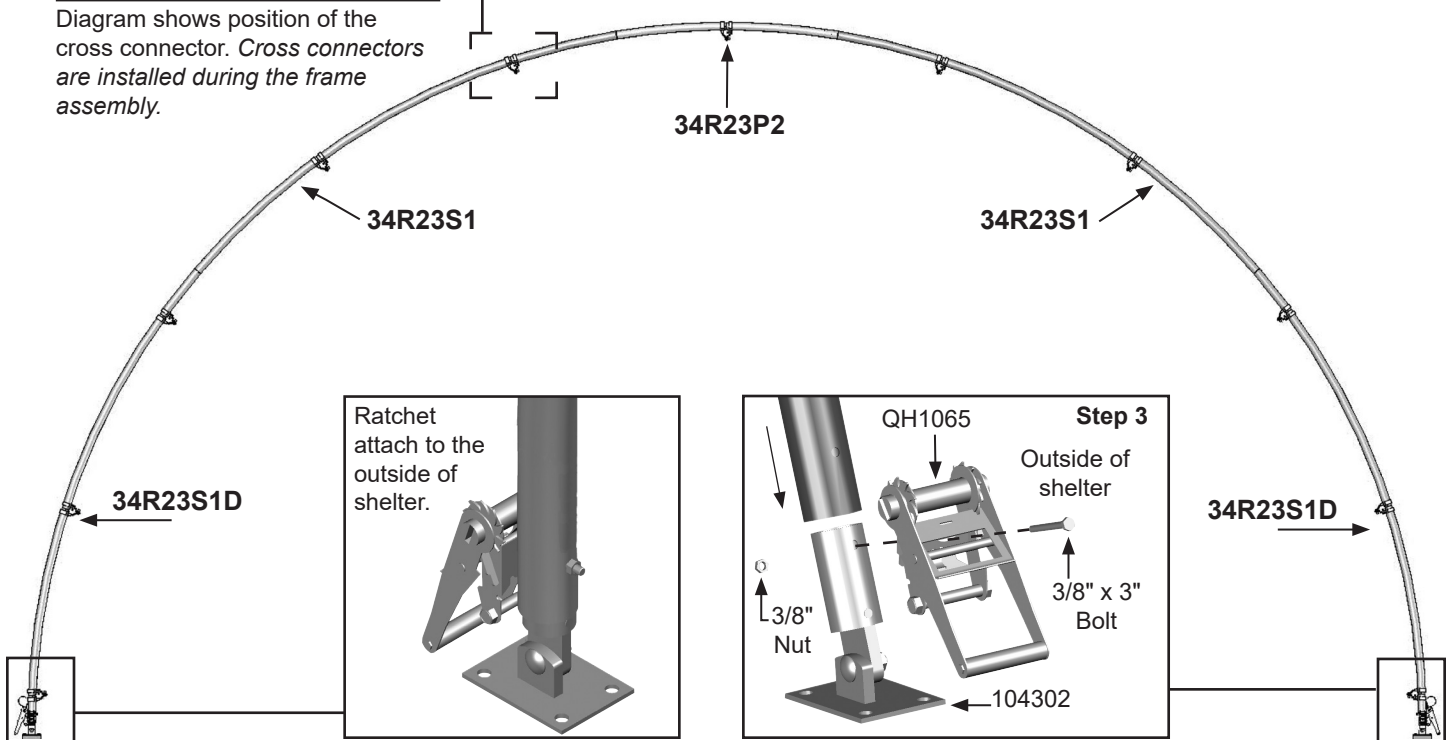

Diagram shows position of the cross connector. Cross connectors are installed during the frame assembly.

ATTENTION: After assembling these interior rafters with attached ratchets, set them aside in an accessible place.

Consult the Side Profile Diagram in the Quick Start section during the frame assembly to set each rafter in the correct position.

Do not place other assembled interior rafters from the next procedure on the same rafter pile.



CLEARSPAN™ POLY BUILDINGS

INTERIOR RAFTER ASSEMBLIES (CONTINUED)

Assemble Interior Rafters Without Attached Ratchets

1. Select the rafter pipes (see End Rafter Assembly) and assemble and secure the pipes as previously described.
2. After securing each pipe joint using one self-tapping Tek screw, attach rafter foot (104302) to the rafter using the 3/8" hex head bolt (FAG363) and nut (FALB04B).

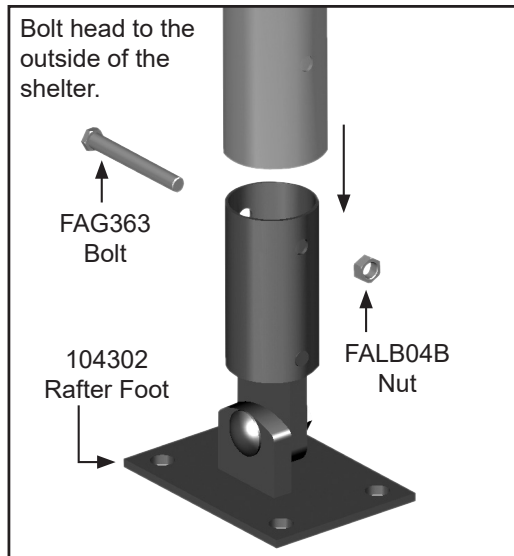

3. Repeat Step 2 to attach the remaining rafter foot.
4. Repeat the above procedure to assemble the remaining interior rafters without ratchets.
5. Place all interior rafters without attached ratchets in a pile separate from either of the other rafter piles.

NOTE: You must be able to access all three rafter piles easily throughout the assembly steps.

FRAME ASSEMBLY

Gather the parts:

- All rafter assemblies
- Purlin pipe 1.315" x 75" swaged (131S075)
- Purlin pipe 1.315" x 73.5" plain (131P0735)

Frame Assembly Procedure

After all rafters are constructed and placed in an orderly fashion for frame assembly, proceed with standing the first end rafter. Forklifts and personnel booms are recommended for lifting and setting the rafters. Consult a construction professional if you are not familiar with construction techniques and erecting similar structures.

ATTENTION: Use the proper lifts. Rafter assemblies are heavy and awkward to handle.

1. Stand the first end rafter and secure it using rope, cable, or some other form of temporary bracing to hold the rafter in position. Use a level (or other leveling device) to plumb the end rafter.

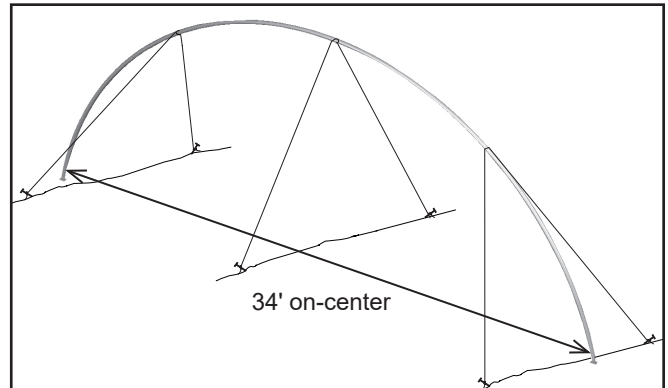

NOTE: Plumbing the end rafter at this stage assists in placing the remaining rafters.

2. Position rafters to maintain width at 34' on-center.
3. Secure the rafter feet to the site (or customer-supplied baseboards) to prevent the rafter from shifting.

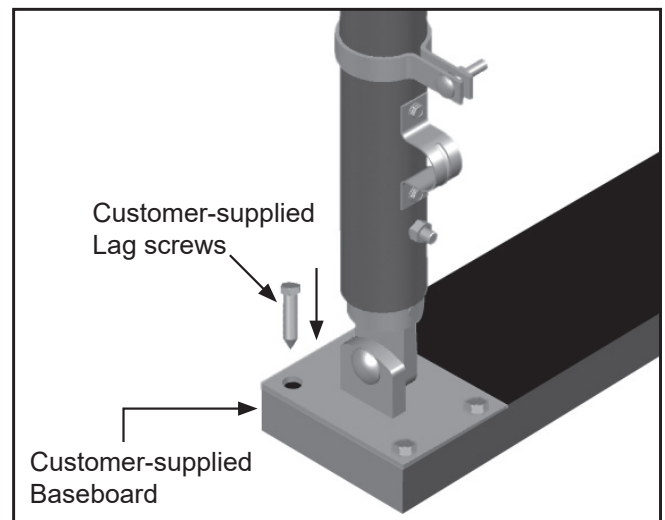

NOTE: The use of a baseboard beneath the feet of the rafters is strongly recommended. The feet then can be secured to the baseboard using the customer-supplied lag screws or other appropriate fasteners.

If used, baseboards should be "pinned" in place to prevent them from moving during assembly. *Anchoring the rafter feet to customer-supplied baseboards is not a substitute for anchoring the frame to the site.*

Consult the MUST READ documentation that shipped with the building for anchoring instructions.

Baseboards can be treated wood or recycled plastic lumber. Contact Customer Service at 1.800.245.9881 for additional information.

FRAME ASSEMBLY (CONTINUED)

4. With the first end rafter standing, plumb, properly secured, and width on-center, set the first interior rafter in place.

IMPORTANT: Consult the Side Profile Diagram in the Quick Start section to determine if the next rafter in line is with or without an attached ratchet.

During the frame assembly, *install all rafters with an attached ratchet in the correct frame location.*

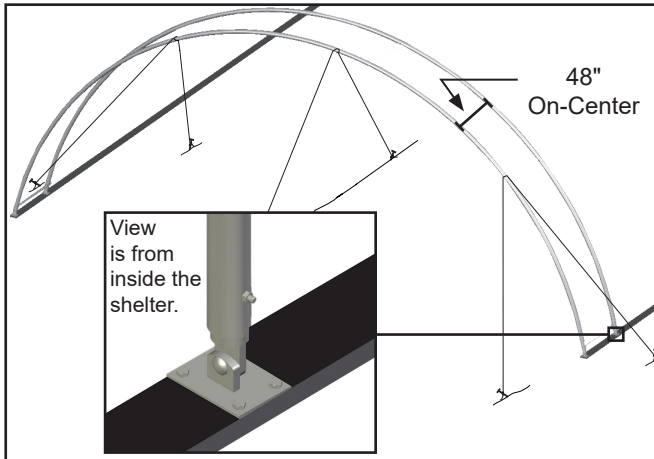

5. Place a cross connector at the top of the inside rafter, align it with the QH1070 pipe strap attached to the end rafter in the same location, and insert the *plain end* of the purlin pipe (131S075) through the connector and through the *pipe clamp at the top of the end rafter.*
6. Verify that both rafters are plumb and properly spaced (48" center-to-center).

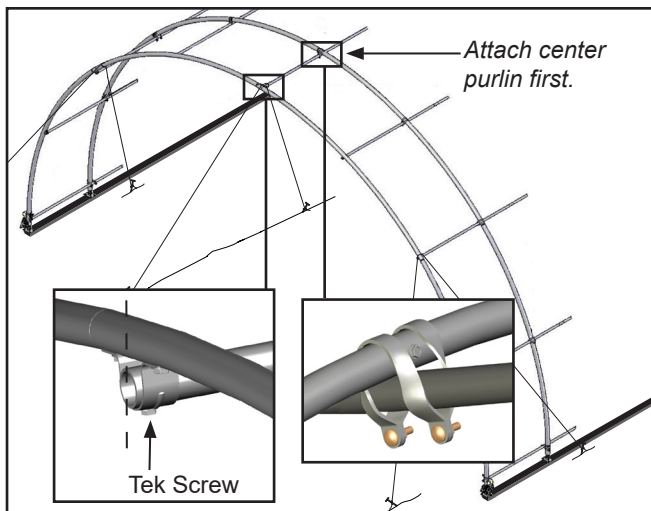

Frame shown may differ from actual frame, illustration purposes only. All cross-connectors will align with the QH1070 pipe straps attached to the end rafters when properly installed.

7. Verify that the purlin does not extend beyond the end rafter and tighten the cross connector at the *top of the interior rafter.* (See dashed line in the insert above.)

8. Return to and tighten the QH1070 pipe strap at the top of the end rafter to secure the purlin.

NOTE: To prevent cover damage, do not allow the purlin to extend beyond the edge of the end rafter. See dashed line in previous diagram for details.

9. Secure the purlin to the QH1070 strap by driving a Tek screw through the strap and into the purlin pipe. See the arrow in the insert of the previous diagram.
10. With the first section of the top, center purlin in position, move to the bottom of the rafter, verify that the rafter spacing between the end rafter and the first interior rafter is 48" on-center, and install the first section of purlin pipe at this location. *Verify that rafters are plumb.*
11. Move to the other side of the rafter and repeat Step 10.
12. Install the first pipe section of remaining purlins. (There are eleven (11) purlins between each rafter.) Consult the Frame Diagram shown earlier in these instructions for purlin location.

ATTENTION: To prevent cover damage, **DO NOT** allow the purlin pipes to extend beyond the end rafter. *To protect the cover, tape all rafter joints with duct tape.*

13. Verify that purlins are running parallel with each other.
14. Return to *each purlin and cross connector* and secure the cross connector to the rafter and the purlin to the cross connector. See the example diagram below.

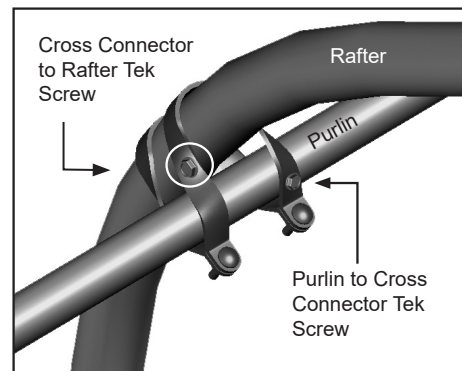

Position Tek screws so they will not contact the cover once it is installed.

15. Repeat the steps to set and secure the remaining interior rafters for the length of the building.

IMPORTANT: During assembly, consult the Side Profile Diagram in the Quick Start section to determine the positions of the interior rafters that include ratchets and those that do not.

16. Finish each purlin run using a 73.5" pipe (131P0735) positioned between the last interior rafter and the final end rafter to complete the assembly.
17. With all rafters in place, continue with the cable assembly procedures.

CLEARSPAN™ POLY BUILDINGS

CABLE ASSEMBLY

Cable assemblies provide diagonal bracing for the building. Each cable assembly includes the following items:

- Cable (2 cables cut to length)
- Turnbuckle (1)
- Cable thimbles (4)
- Cable clamps (4)

ATTENTION: Consult the diagram on the next page to identify cable assemblies and cable locations.

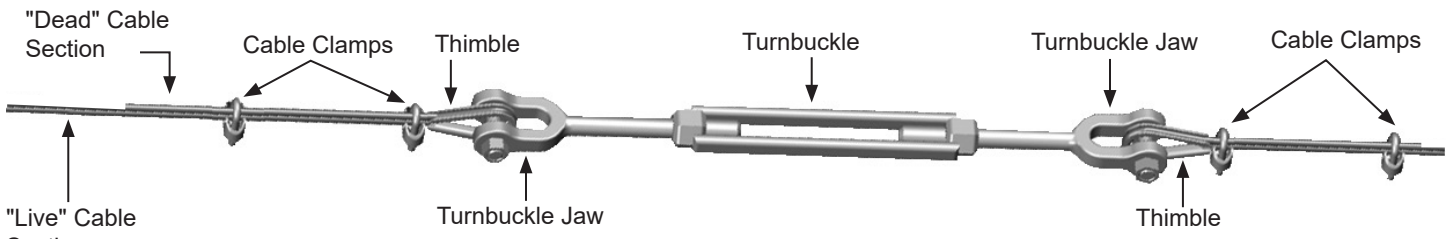

Typical Turnbuckle Assembly

NOTE: For each cable assembly, four (4) additional cable clamps are used to attach the cable assembly to the frame. In addition, Cable C assemblies require an additional cable thimble at each lower end to complete the connection to the band clamp attached to the rafter leg. See Side Profile Diagrams. Consult the Cable Diagram on the following page and the Side Profile Diagram in the Quick Start section for clarification and cable locations.

Cable Assembly Procedure

1. Using the Side Profile Diagram in the Quick Start section (and others) as guides, measure the distance needed on the frame and cut the cable to the proper length for each assembly. Remember to account for the turnbuckle and the cable length needed to attach the thimbles at each end. (Extra cable has been sent for the cabling.) Make a single assembly *before* making them all. This allows a check to be sure the correct length has been cut. Make the necessary length adjustments as needed before making additional assemblies. *Always measure before cutting the cable.*

ATTENTION: One (1) turnbuckle and two (2) cables are used for each cable assembly type. For best results and the least cable waste, use the diagram on the following page and measure the distance required for a specific cable. Additional cable length is needed to anchor the cable to the frame and to attach the cable sections to the turnbuckle.

Measure and cut the follow assemblies as needed:

- Cable Assembly A: 16 cable lengths; 8 turnbuckles
- Cable Assembly B: 16 cable lengths; 8 turnbuckles
- Cable Assembly C: 16 cable lengths; 8 turnbuckles

2. Place one cable thimble approximately twelve inches (12") from the end of a cable section and wrap the cable around the thimble as shown in the figure to the right.
3. Grasp both sections of the cable near the thimble and position one cable clamp one inch away from the thimble as shown above.

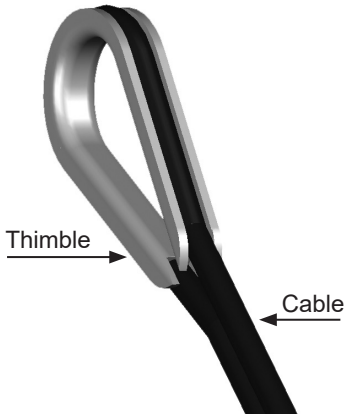

NOTE: Position the clamp on the cable with its U-bolt portion over the short/"dead" cable section.

4. With the saddle portion of the cable clamp in position on the "live" cable section, thread the nuts onto the U-bolt section of the clamp and tighten slightly to maintain the position of the clamp on the cable.

CABLE ASSEMBLY (CONTINUED)

5. Install a second cable clamp on the cable six to eight (6"-8") inches from the first clamp and tighten both clamps.
6. Remove the bolt from the jaw of the turnbuckle and position the cable end with the thimble into the turnbuckle jaw.
7. Insert the bolt through the turnbuckle jaw and the cable thimble, thread the nut onto the bolt, and tighten to secure the cable to the turnbuckle.
8. Repeat Steps 2-7 for the remaining length of cable for this assembly.
9. Open the turnbuckle to its longest position and set the assembly aside.
10. Repeat the above procedure for all remaining assemblies. Length of upper cables may differ from the side cables. *Always measure length on the frame before cutting the cables.*
11. With all cables assembled, move to the top of the fifth (5th) rafter and drill a 5/16" hole down through the rafter and top, center purlin. This is the rafter-purlin connection where the ends of the upper cables are wrapped and secured. See the insert in the diagram below for Steps 11 and 12.
12. Insert the 5/16" x 5" carriage bolt (FAH325B) down through the 5/16" hole, add a 5/16" nut, and tighten.
13. Repeat Steps 11 and 12 for the remaining rafter-purlin position *at the other end of the frame*.
14. Attach the cables to the assembled frame. See the diagrams below and in the Quick Start section of these instructions for details and cable locations. The cable assembly length and positions are the same for the other side and end of the frame. *Verify that the turnbuckles are fully extended before attaching the cables to the anchored frame.*

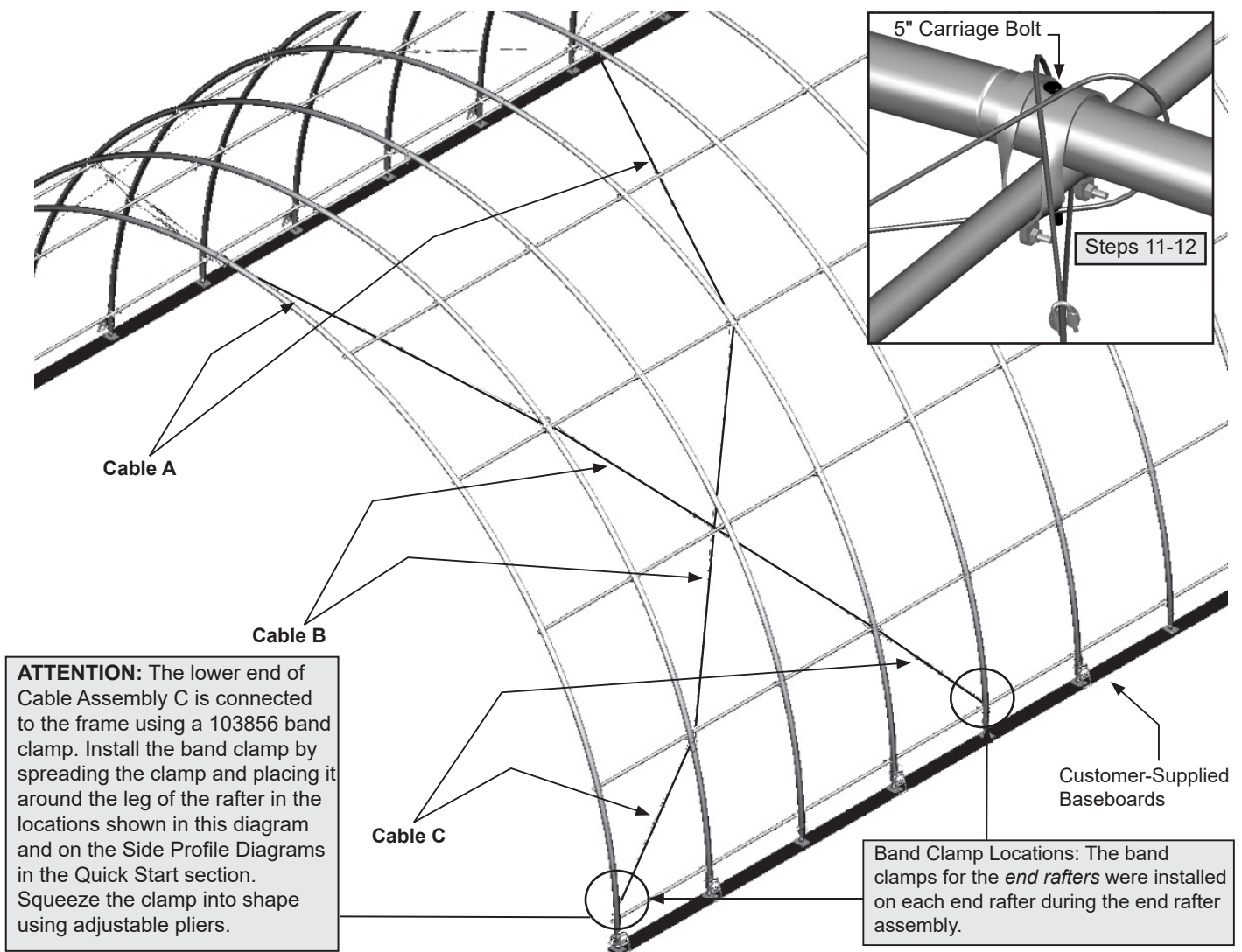

ATTENTION: The lower end of Cable Assembly C is connected to the frame using a 103856 band clamp. Install the band clamp by spreading the clamp and placing it around the leg of the rafter in the locations shown in this diagram and on the Side Profile Diagrams in the Quick Start section. Squeeze the clamp into shape using adjustable pliers.

Band Clamp Locations: The band clamps for the *end rafters* were installed on each end rafter during the end rafter assembly.

CLEARSPAN™ POLY BUILDINGS

CABLE PLACEMENT

The diagram and inserts below identify the placement and proper way to attach the cable assemblies to the building.

Do not tighten the cables until the frame is properly and securely anchored to the site as described in the Must Read document.

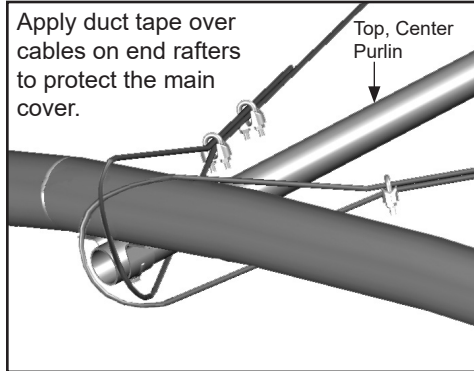

ATTENTION: Install a carriage bolt in this location at both ends of the shelter.

Drill through the rafter and purlin to install the bolt.

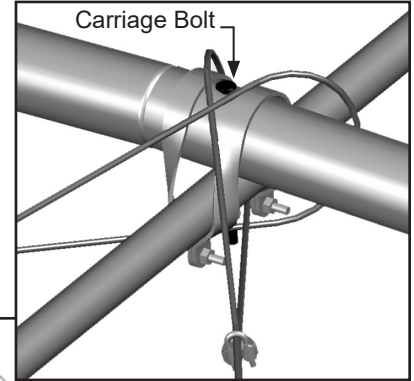

Carriage bolt runs through rafter and top center purlin on the 5th rafter at each end.

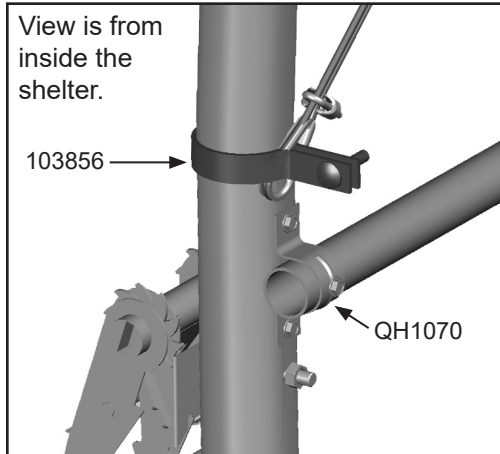
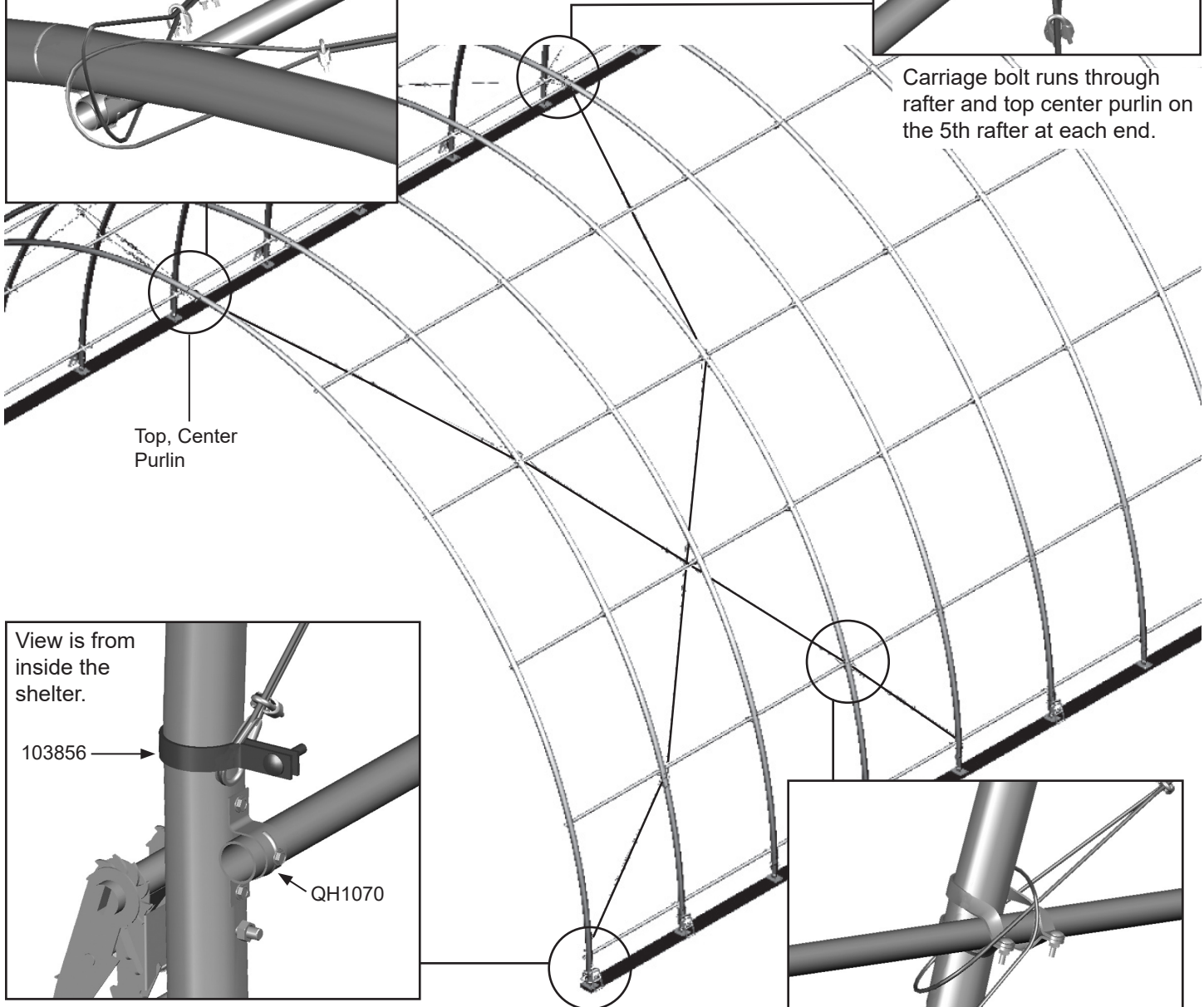

Attach the band clamp (103856) above the lowest pipe strap (QH1070) on the end rafters only. Once the cable is attached and the clamp is tightened, secure the clamp to the rafter using a Tek screw.

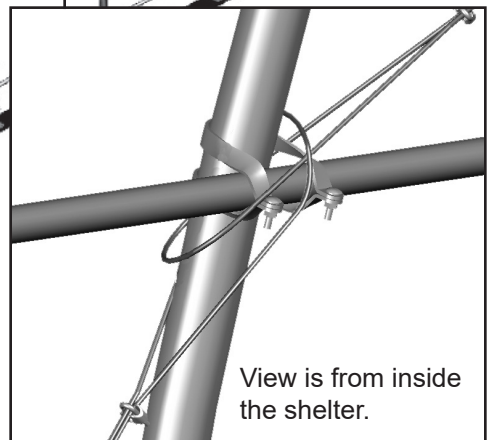

NOTE: The positions of the cable assemblies are identical for the opposite side and the remaining end of the building that are not shown. Consult the Side Profile Diagram in the Quick Start section for rafter spacing and cable locations.

ANCHOR THE SHELTER

After installing all cable assemblies, anchor the frame. Once the frame is anchored properly, continue with these instructions.

⚠ WARNING: Securing the rafter mounting feet to baseboards set on the site is not a substitute for properly anchoring the shelter. You must anchor the shelter as described in the MUST READ document.

FAILING TO PROPERLY ANCHOR THE SHELTER WILL RESULT IN DAMAGE TO THE SHELTER AND MAY CAUSE PERSONAL INJURY.

READ THE MUST READ DOCUMENT TO PROPERLY ANCHOR THE SHELTER.

TIGHTEN THE CABLING

The positions of the cable assemblies are identical for the opposite side and the remaining end of the building that are not shown in the previous diagram. For cable locations for your building, consult the Quick Start section (back).

1. After attaching all cable assemblies to the building frame, verify that each band clamp is tight and secured to the rafter leg using a Tek screw.
2. Return to the first set of turnbuckles and tighten the cables.

NOTE: Tighten the cables in each section evenly so that the frame remains plumb.

3. After one set of cables is tightened, move to another set and repeat the steps to tighten those cables.
4. Repeat this process until all cables are tight.
5. Continue by installing the QH1061 end ratchets for the bonnet portion of the main cover. These are the four (4) remaining ratchets.

INSTALL THE RATCHETS FOR THE MAIN COVER

The ratchets are attached to the legs of end rafters on the outside of the rafter leg.

Gather the parts: Four (4) small ratchets (#QH1061) and Tek screws (#FA4482) to secure ratchets to the end rafters.

Complete the following steps to secure the ratchets to the rafter legs.

1. Locate the four (4) small ratchets (#QH1061) and attach these to the outside of the two end rafters as shown. Attach the ratchets using Tek screws (FA4482).

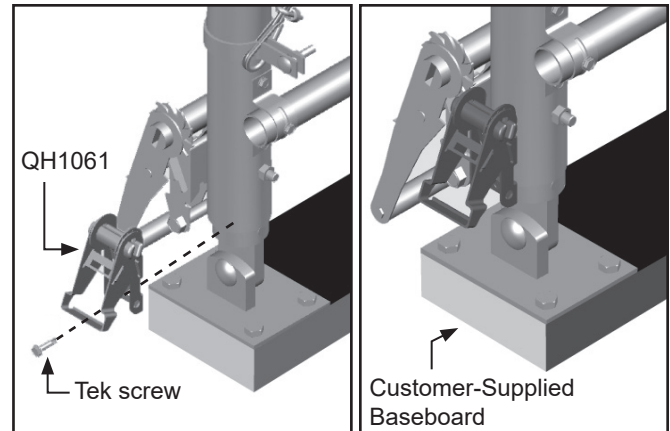

NOTE: If you cannot find the QH1061 end ratchets, verify that these were not attached to an interior rafter during the rafter assembly. Remove from the interior rafters if needed and install on the end rafters.

2. After all end ratchets are installed, continue with the final frame check and main cover installation steps.

FINAL FRAME CHECK

1. Return to the frame connections and verify that all bolts are tight.
2. Verify that each purlin splice is secured with a Tek screw.
3. Verify that each purlin is secured to the cross connector and that each cross connector is secured to the rafter pipe. See Page 11 if needed.
4. Inspect the frame for any sharp areas that could damage the cover. If found, reposition components or tape with layers of duct tape.
5. Verify that all bolts are positioned with the heads to the outside of the frame. Tape the bolts, rafter joints, and cable connections *before* installing the cover.
6. Continue by installing the main cover.

CLEARSPAN™ POLY BUILDINGS

PREPARE MAIN COVER

Gather the parts:

- Pipe 1.66" x 99" swaged
- Pipe 1.66" x XX" plain: The XX refers to the length of the plain pipe needed to reach the end of the frame and to complete the conduit. Consult the Side Profile Diagram in the Quick Start section of these instructions for your building to identify this pipe length.
- Main cover
- Tek screws

Assembly Procedure

NOTE: When handling the main cover and setting it in position, do not pull on the end straps. They will pull out of the cover bonnet pocket. *Do not insert any cover conduit into a cover pocket that includes a pre-installed strap.*

⚠ WARNING: To prevent damage to the cover and to prevent serious personal injury, DO NOT attempt to install the main cover on windy days.

1. Assemble two main cover conduits. Start each cover conduit assembly with one plain pipe and add swaged pipes to arrive at the length of the frame. *This cover conduit is identical to the on-center length of the shelter.* Once assembled, insert the cover conduits into the side pockets of the main cover. The conduits are used to tighten and secure the main cover to the frame. *Consult the Side Profile Diagram in the Quick Start section for pipe identification.*

- a. Locate all sections of pipe needed to assemble the cover conduit.
- b. Insert the swaged end of each pipe into the plain end of another pipe until the conduit is assembled.
- c. Secure each pipe joint with a Tek screw.
- d. Use duct tape to tape over each Tek screw.

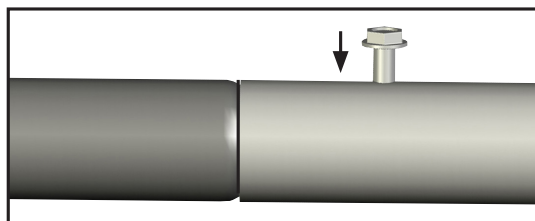

2. After assembling the cover conduits, locate the main cover and unfold it on a clean, smooth surface near the frame. Unfold the main cover with the inside surface facing up and the straps positioned at the front and back of the frame.

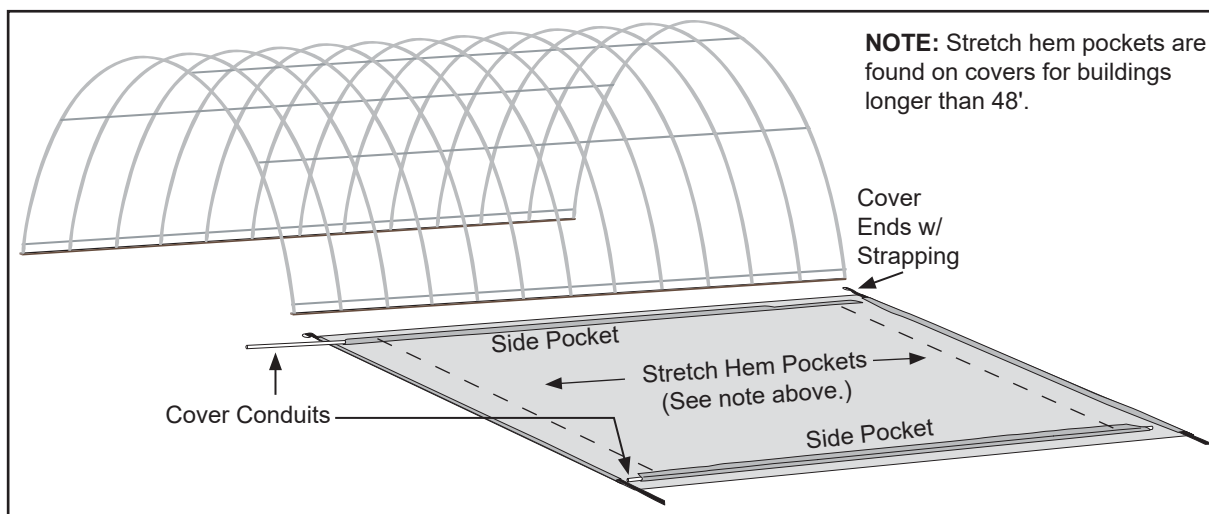

3. Align the cover ends with the front and back of the shelter and insert one cover conduit into each side pocket of the main cover.

NOTE: Shelter shown above may be of a different style or length than actual shelter.

4. Continue by pulling the cover up and onto the frame.

ATTACH MAIN COVER

Gather the parts:

- Main cover (with conduits inserted)
- Ropes (provided by customer) or strap long enough to reach over the frame
- Box cutter or utility knife

⚠ WARNING: To prevent damage and injury, do not leave the cover unattended if it has not been properly secured. The ropes can be used to temporarily keep the cover from blowing off the frame.

Assembly Procedure

1. To pull the cover over the frame, attach ropes or straps to both ends of the cover conduit positioned *furthest from the frame*. Wrap the rope around the conduit a few times to prevent it from slipping off.

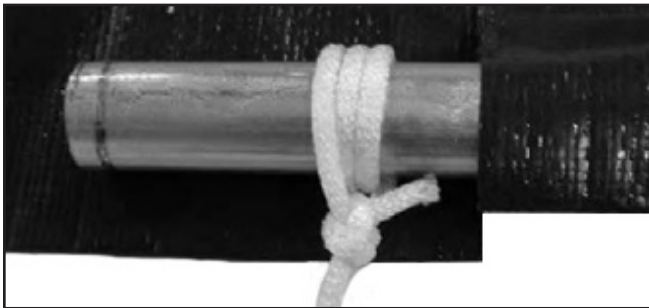

NOTE: Depending on the length of the cover it may be necessary to attach additional ropes to the cover conduit between the end ropes by cutting a small opening in the cover pocket and tying the rope around the conduit. **DO NOT** cut through the main cover. *Cut through the conduit pocket only.*

2. With all ropes attached to the cover conduit, lift and carry the conduit and cover toward the base of the assembled frame.
3. Set the conduit down, toss the ropes over the frame, and pull the cover into position. Position one person at each rope. *Verify that the cover pockets are to the inside of the building. This will be the underside of the cover when it is pulled into position on the frame.*

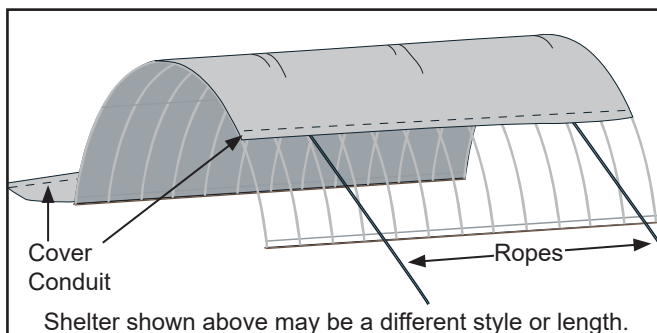

NOTE: Use lifts and additional assistants (if needed) to help pull the cover up and over the frame.

4. Once the main cover is pulled into position, center the cover on the frame (end-to-end and side-to-side).

⚠ WARNING: To prevent damage and injury, do not leave the cover unattended if it has not been properly secured.

5. Locate the black straps at the front and rear hems and feed the straps through the center slot in each end ratchet. Operate the ratchet to wrap the strap onto the center hub just enough to keep the strap secure.

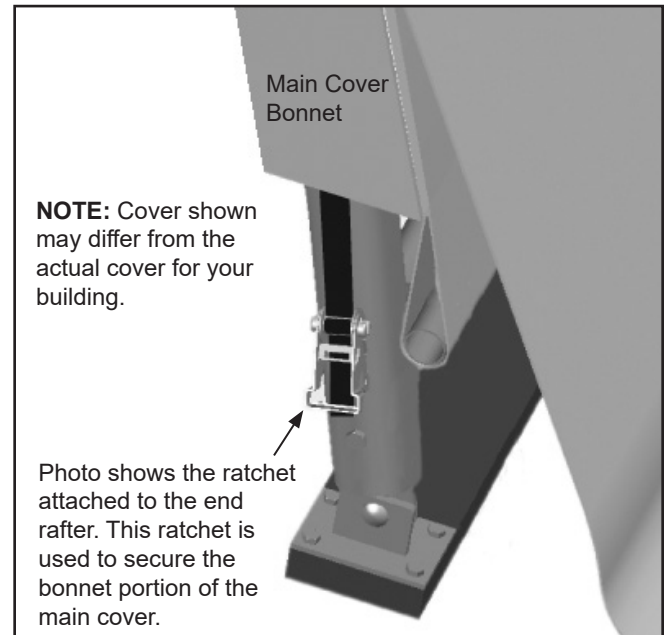

NOTE: Do not tighten completely at this time. This helps to temporarily secure the cover.

6. Tie the ropes (or straps), used to pull the cover into position, to the frame to help hold the cover.
7. Move to the other side conduit of the cover and temporarily secure that side of the cover to the frame.

NOTE: Tie short pieces of rope to the ends of the side conduit and directly across from the ropes or straps tied to the other side conduit to temporarily secure the cover to the frame. Once side straps are installed and slightly tightened, the temporary ropes can be removed.

8. Continue with the installation of the side straps.

CLEARSPAN™ POLY BUILDINGS

INSTALL THE MAIN COVER SIDE STRAPS

The side straps wrap around the conduit through slits created in the side conduit pocket. The strap ends of each strap are then fed into each side ratchet attached to the rafter legs and slightly tightened to keep the cover in position.

Required parts and tools:

- CC5391 - 2" strap (Photos may show a different strap and ratchet setup. Procedure is similar.)
- Tool to cut slits in cover conduit pockets

Complete these steps to install the side straps:

1. Move to one side ratchet attached to a rafter and cut a slit in the conduit pocket above the conduit and in line with the ratchet.



Photo above shows using a utility knife to cut a slit above the conduit, which has been inserted into the main cover side pocket. Cover, rafter, and frame design differ from actual shelter. Procedure is the same.

NOTE: If ropes were used at these locations when the main cover was pulled in place, a slit in the cover pocket may already be present.

When creating the slit in the pocket for the strap, *do not cut the main cover. Cut only the pocket material.*

2. Select one of the tie down straps (CC5391) that shipped with the building and insert one end of the strap through the slit and around the cover conduit.



NOTE: Depending on the where the ratchet is attached to the rafter, cut the strap to the proper length if needed.

3. Feed both ends of the strap through the slot in the ratchet and slightly tighten the strap.



NOTE: Do not tighten completely at this time.

Frame and ratchet location differ from actual frame. Steps to install the main cover are similar however.

4. Repeat the previous steps to install and slightly tighten the remaining side straps.

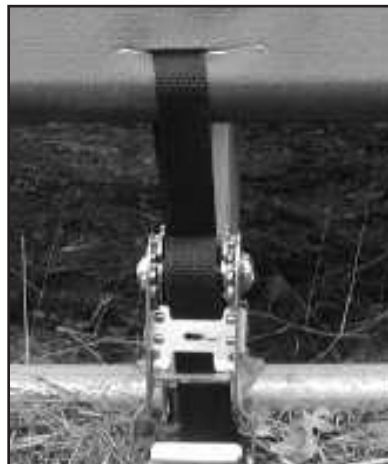

NOTE: Do not tighten completely at this time.

5. After all side straps are in place and slightly tightened and the cover is centered evenly on the frame, complete the following steps to install the PVC cover conduit.

NOTE: *The following procedure applies to shelters longer than 48'.*

If your building is 48' in length or shorter, skip the next section and continue by tightening the side ratchets as described on Page 21.

INSTALL THE PVC CONDUIT FOR MAIN COVER ENDS

Complete this section if the building is longer than 48'. The PVC conduit is inserted into notched pockets at each end of the main cover. Strapping is then threaded around the conduit and the end rafters. This strapping is evenly tightened to stretch the main cover end-to-end.

Required parts and tools:

- LJ2842 (3/4" PVC conduit) and 103620 (1" strap)
- Duct tape, Tek screws, and driver for Tek screws
- Tool to cut strap, a lift or ladders to reach top of frame, and assistants to install and tighten strap

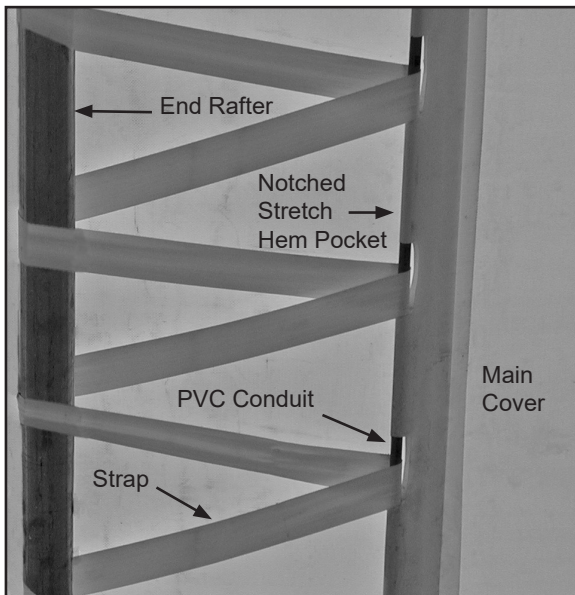

Photo shows the stretch pocket and the conduit and strapping as installed for a similar main cover. View shows the cover as seen when standing inside the frame looking up at the end rafter.



Photo above shows a similar cover and the location of the stretch pocket. Cover is shown with the underside facing up, which is the side visible from inside the frame when the cover is installed.

PVC conduits are installed near the ends of the main cover to provide an additional tie-down position. Complete these steps to install the conduit and strapping for the stretch pockets of the main cover.

1. Take the first section of PVC conduit and feed it into the stretch pocket from the bottom at one end of the cover. *Insert the plain end of the conduit into the pocket so the next section can be joined to the first.*

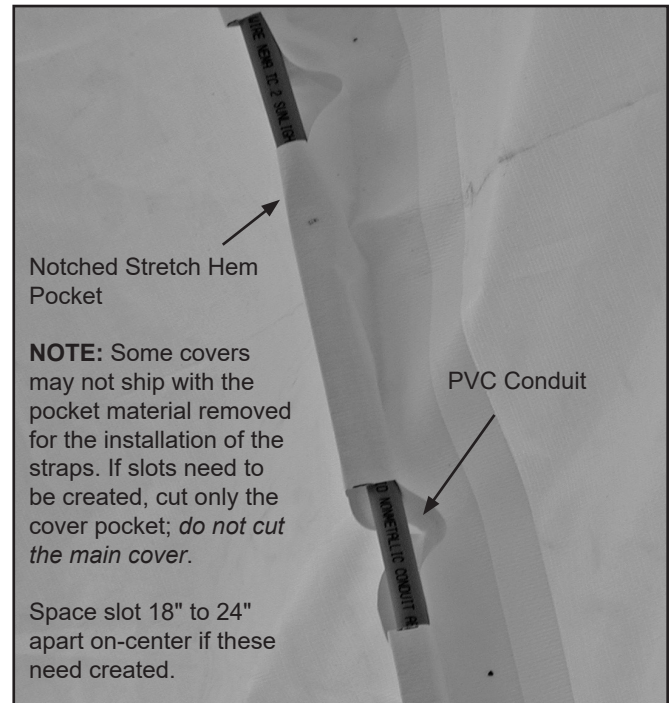

Photo shows the notched stretch pocket and the installed PVC conduit at the end of a similar main cover.

2. Once the bell end reaches the pocket, take another section of PVC conduit, insert the plain end into the bell end of the previous section and secure the joint using a Tek screw or customer-supplied PVC glue.



NOTE: Wrap the Tek screw and joint using duct tape.

CLEARSPAN™ POLY BUILDINGS

INSTALL PVC CONDUIT (CONTINUED)

3. Repeat the steps and continue to assemble and feed the PVC conduit into the pocket.
4. Once the PVC conduit is fully assembled, secured at the joints, and inserted into the pocket, repeat the steps for the remaining end of the main cover.
5. With both PVC conduits assembled and installed, verify that the cover is centered on the frame (side-to-side and end-to-end) and move to one end rafter.
6. Take the rope or strap used to pull the cover and cut a few sections long enough to tie the PVC conduit to the end rafter in evenly spaced locations. See example in the photo below.

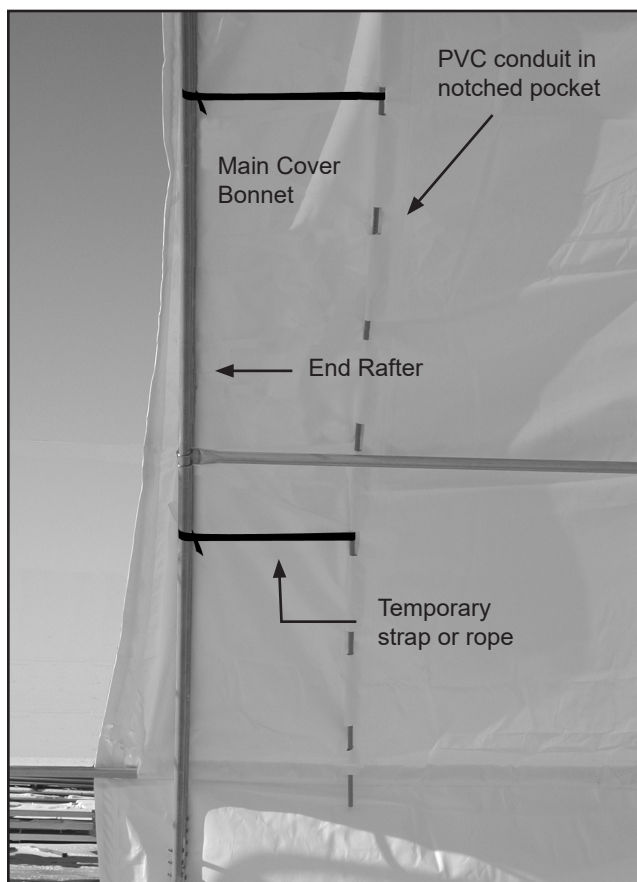

Photo shows temporary strapping tied between the PVC conduit and the end rafter to keep the main cover centered on the frame as the strapping at the other end of the frame is installed. Cover used for illustration only. Actual cover may differ from what is shown.

7. Move to the end of the frame opposite the end where the temporary strapping were tied, take one end of the bulk roll of 1" strapping, and weave it around the end rafter and PVC conduit.

8. Continue weaving the strap around the end rafter and PVC conduit working up and over the rafter and down to the other end of the PVC conduit.

NOTE: Keep the strapping snug during this step, but do not over tighten. Also, maintain an even distance between the top of the end rafter and the PVC conduit.



Photo shows how to weave strap around the conduit inside the main cover pocket and the end rafter. (Cover and rafter shown differs from actual cover.) Distance between the conduit in the pocket and the end rafter is even.

9. After weaving the strapping, cut the strap and tie it to the end rafter to temporarily secure it.
10. Take the remainder of the bulk strap roll, move to the other end of the frame, and repeat the steps to weave the strap between the PVC conduit and the top of the end rafter.

NOTE: The temporary rope or strapping at this end can be removed once the main strapping is in place.

11. After the strap is completely installed at this end, cut the strap to length and tie it to the end rafter.

INSTALL PVC CONDUIT (CONTINUED)

12. Beginning at either end of the cover, tighten the strap. The strapping will pull against the strapping installed at the other end of the frame.

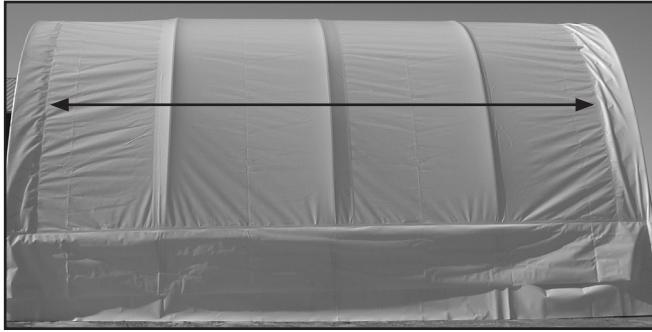

Shelter shown above may be a different model and length. Photo used for illustration purposes only.

NOTE: Maintain an even distance between the end rafter and the PVC conduit as the strap is tightened.

Also check that the bonnet portion of the main cover overlaps the end rafters evenly at both ends *before* stretching the cover. Check this periodically as the cover is stretched.

If the side straps are too tight and prevent the cover from stretching end-to-end, loosen but do not remove the straps as needed and continue.

13. Once the strap is tight at one end, cut it to length (if needed) and tie it to the other leg of the same end rafter.
14. At each end of the stretch hem strap, drive a Tek screw through the strap and into the back side of the rafter to secure the strap to the rafter. This helps keep the strap tight and in position.
15. Return to the other end of the frame and tighten that strapping (if needed) to complete the stretching of the main cover from end-to-end. Secure the strap using a Tek screw at each end (Step 14).
16. Continue by tightening the side ratchets.

TIGHTEN THE SIDE RATCHETS

Verify that the cover is in the desired position and centered on the frame. (Loosen and reposition if needed.) Continue with these steps to tighten the side ratchets.

1. Move to the side ratchets attached to each leg of one rafter. Begin at an inside rafter near the center of the frame.
2. With an assistant at one side ratchet and someone at the other side ratchet on the same rafter, tighten the ratchets to secure the cover.

Tightening the ratchets at the same time on the same rafter helps keep the cover centered and results in a more uniform appearance.

3. Move to another rafter and repeat the steps to tighten the side ratchets attached to that rafter.

NOTE: If the strap builds up in the ratchet, loosen the ratchet, remove some of the strap, and retighten.

4. After all side ratchets are tight, position someone at each ratchet attached to the end rafter where the bonnet straps of the cover were previously inserted.

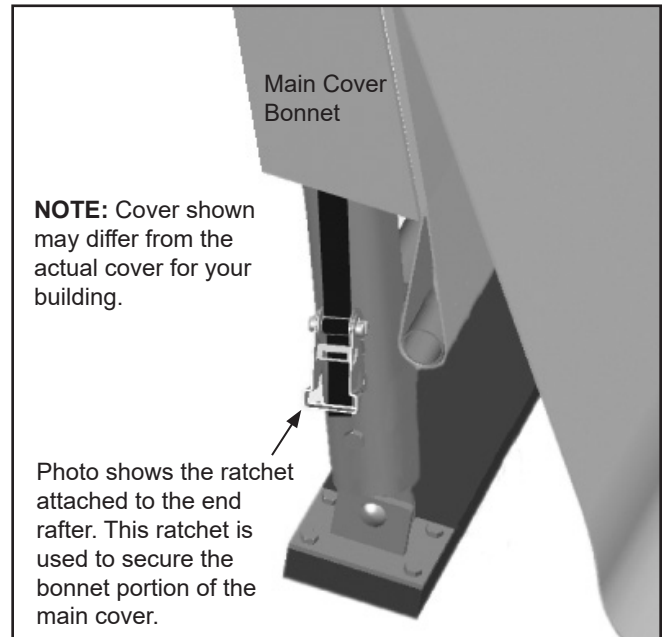

5. Tighten the end ratchets to secure the bonnet portion of the main cover.
6. Move to the other end of the building and secure the bonnet at that end.
7. Read the care and maintenance information that follows.

CLEARSPAN™ POLY BUILDINGS

SHELTER CARE AND MAINTENANCE

Proper care and maintenance of your shelter is important. Check the following items periodically to properly maintain your shelter.



Space below is reserved for customer notes.

- Regularly inspect the main cover and panels (if equipped) to see that these remain tight and in proper repair.
- Check the cable turnbuckles and cable clamps to see that these remain tight. Tighten as needed. Check the cable to verify that it is not worn, wearing on a frame member, or touching the main cover or end panels (if equipped).
- Check connections and all fasteners to verify that they remain tight.
- Do not climb or stand on the shelter at anytime.
- Remove debris and objects that may accumulate on the shelter. Use tools that will not damage the cover when removing debris.
- Remove snow to prevent excess accumulation. Use tools that will not damage the cover when removing snow.
- Check the contents of the shelter to verify that nothing is touching the cover or the side panels that could cause damage.
- Check the anchoring system to ensure that all components are tight and in good repair.
- Inspect all building components regularly. Replace all worn or damaged parts promptly.
- If the shelter is moved, inspect all parts and connections before reassembling.
- For replacement or missing parts, call 1.800.245.9881 for assistance.

NOTE: With the exception of Truss Arch buildings, ClearSpan™ shelters and greenhouses *do not* have any tested loading criteria.



QUICK START GUIDE

34' Wide Free-Standing Building

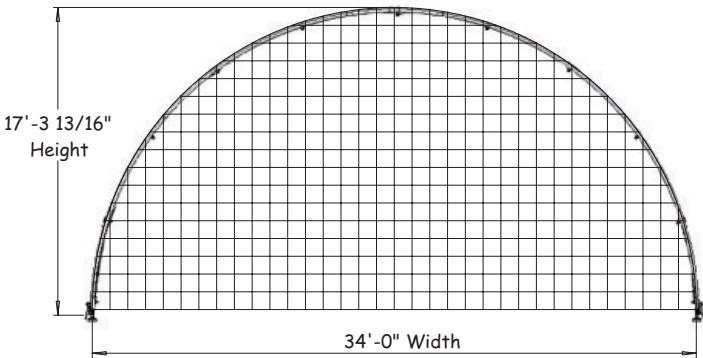

FRONT
Grid Represents 12" Squares

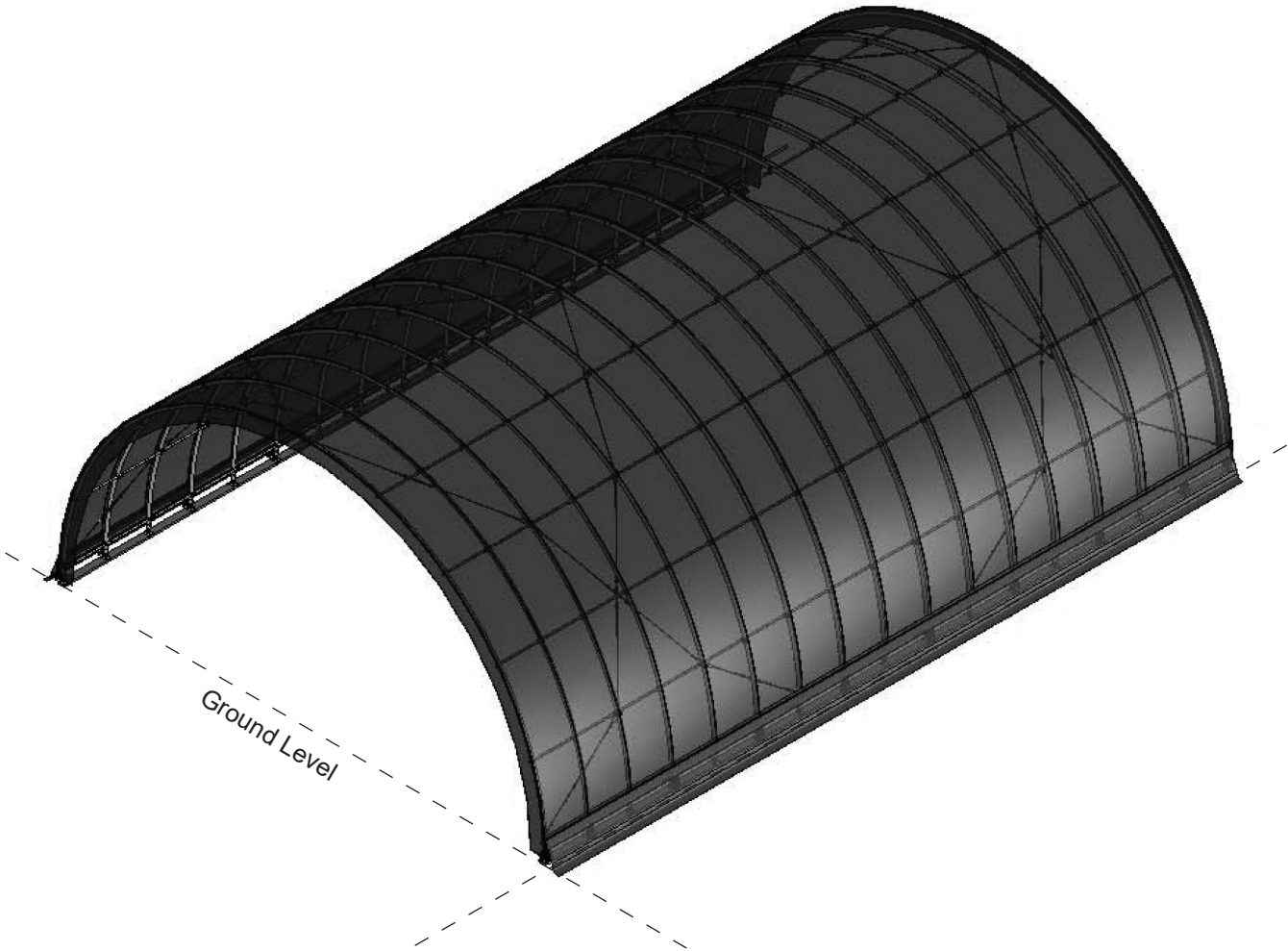

Frame shown may differ in length from actual frame.

CONNECTIONS

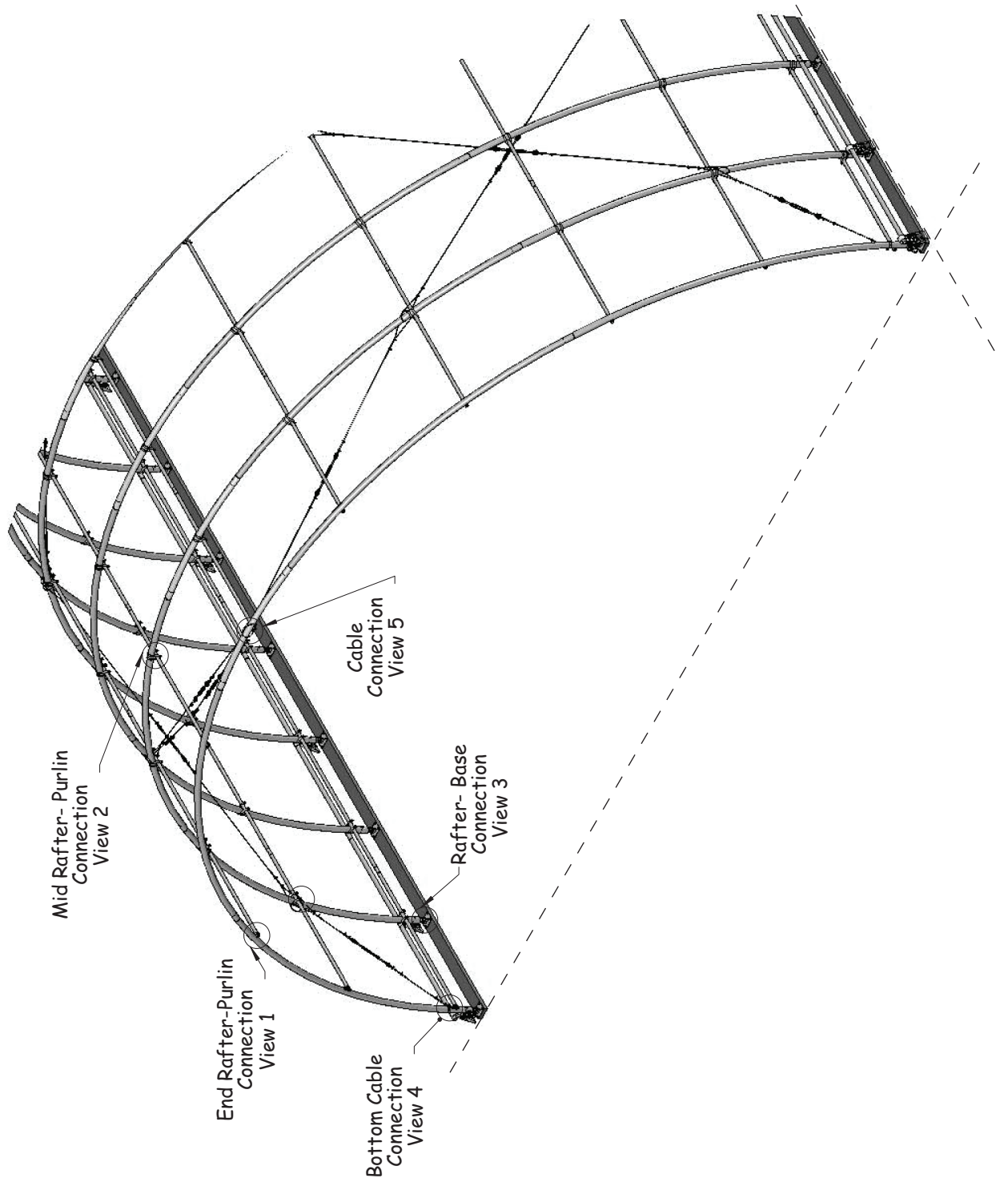

CONNECTION - DETAILS

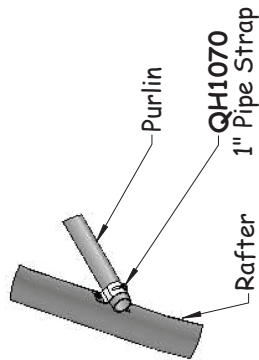

View 1
End Rafter - Purlin
Connection

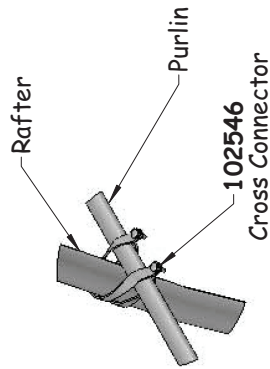

View 2
Mid Rafter - Purlin
Connection

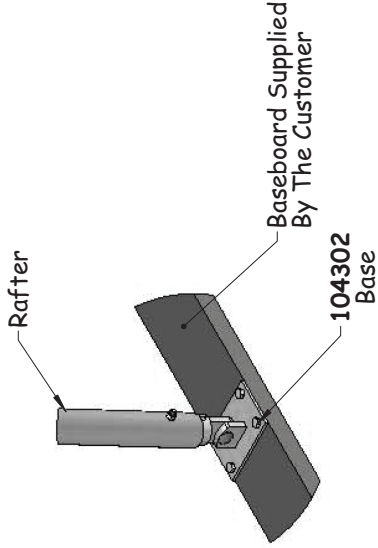

View 3
Rafter - Base
Connection

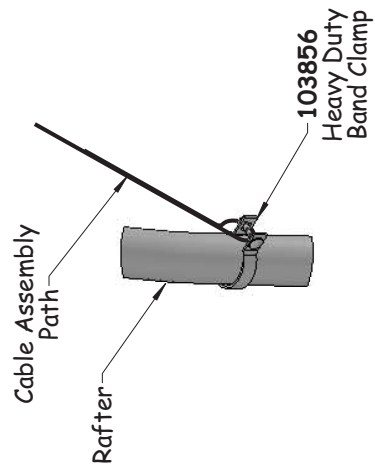

View 4
Bottom Cable
Connection

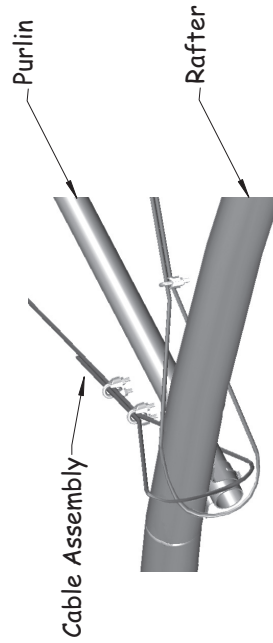

View 5
Cable Connection